

# Energy Efficient Modes of Distribution Power Supply Systems with Different Vector Group of Transformer

Denys R. Zemskyi

Dnipro National University of Railway Transport named after  
academician V. Lazaryan  
Dnipro, Ukraine  
d.zemskyi@ukr.net

Dmytro O. Bosyi

Dnipro National University of Railway Transport named after  
academician V. Lazaryan  
Dnipro, Ukraine  
dbs@mm.st

**Abstract** — The article is devoted to the experiment, what was performed on the local distribution networks with poor power quality. As a rule, these networks are subsystem of AC traction power supply system, and their design causes voltage unbalance and other power quality problems in consumers. Often, the network is powered by transformers with different vector groups, therefore their parallel operation is impossible. The purpose of the experiment is to assess the effect on energy quality of a regime with sources on both sides. The quality of electrical energy was estimated, considerable attention is devoted to unbalance voltage. Using the statistics methods measurement data are studied. During the experiment, the energy quality improved when the parallel mode was used. The concept of smart grid has been proposed to reduce energy losses for dynamic power management.

**Keywords** – different vector group, power quality, AC traction power supply, non-traction customers, voltage unbalance

## I. INTRODUCTION

Isolation of electrical network operation is long past. The united electric power system in the state is typical of many industrially developed states, and there are already facts of the unification of national electric power systems into supranational ones. These connections allowed generating companies to share the economic benefits of building large electric generating units to serve their combined electricity demand at the lowest possible cost.

The voltage level and phase relationship between the various components of the system are important factors during the integration of different systems. The discrepancy is the cause of the appearance of excess power flow and subsequently losses in the system [1, 2].

These problems are often found in systems like traction power systems [3], which are forced to be powered from different parts of the system and must operate in parallel. In addition, adjacent substations have different vector groups due to the different method of connecting to the primary voltage network (Fig. 1). The reason for this is the balancing of currents in High Voltage Transmission System from the influence of single-phase traction load. But the power supply of three phases at the same time from traction substations is not possible, which degrades the reliability and quality of electric power transmission via local distribution networks, which are connected to traction power buses of 27,5 kV from AC railway. It is typical that the

transmitting power line consists of two wires and non-traction consumers take current from these wires and rail. These lines are called the “two wire-rail line” or “TWR line” due to this design feature.

The design and connection of the TWR line with the traction power supply system causes degradation of power quality and reliability of power supply. The relationship of negative factors and their board are shown in the Fig. 2. The total length of TWR lines is about 4,369 km in Ukraine. But only some of them (e.g. is about 100 km long at Odes’ka railway) can be powered from both adjacent substations due to identical vector groups of transformers.

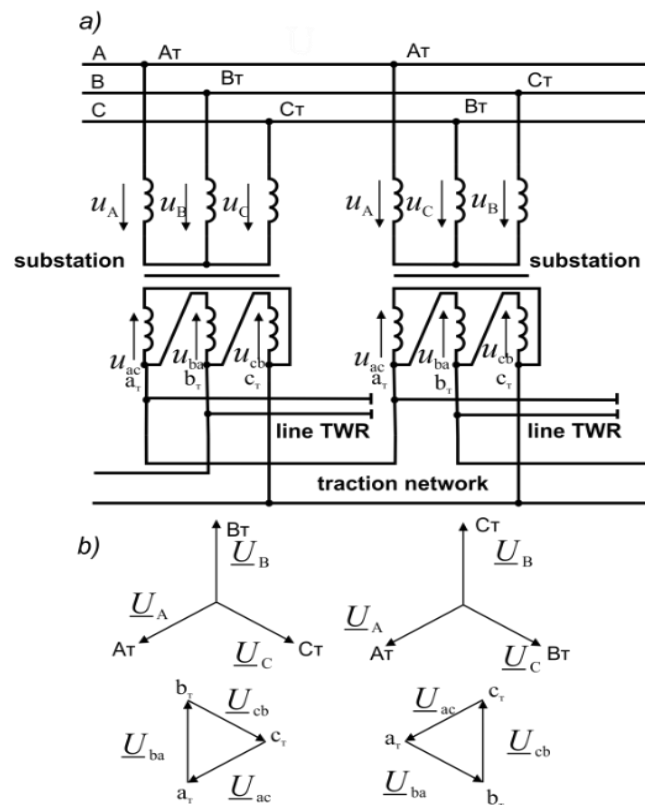

Fig. 1. Railway Electrification System and High Voltage Transmission System a) Schematic diagram b) Vector diagrams of transformer windings

Publications about the quality of energy in the power line confirm these findings [1, 4, 5]. There are research results in various parts of the railway line, where the quality indicators

of the TWR power line exceeded the boundary values, for example: unbalance voltage in the range from 7 to 10,5%, total harmonic voltage distortion in the range from 8,5 to 12,7% [4].

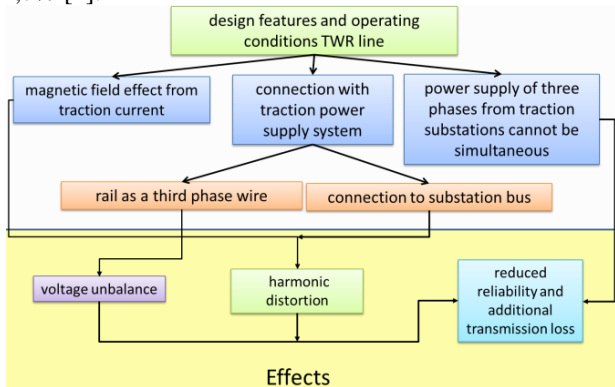

Fig. 2. The relationship between the design and quality of electricity

Government program for the development of the energy sector require reducing losses and improving the reliability of electricity supply [6]. On the other hand, in Ukraine there was a liberalization of the electric power market, and the consumer received the right to choose an energy company at his own discretion. The quality of the energy supplied may be decisive when choosing a supplier.

Phasing device in this case will allow the use of parallel power (Fig. 3).

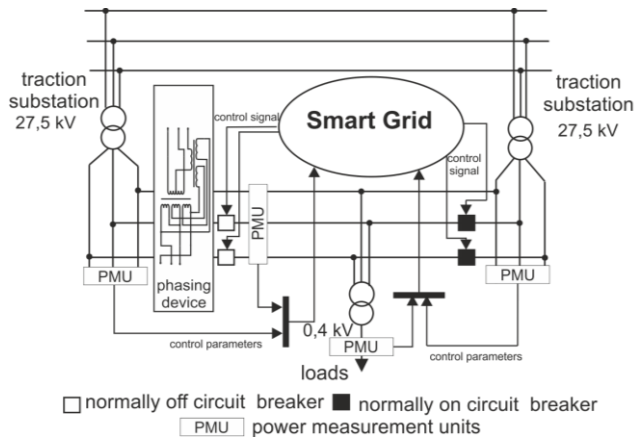

Fig. 3. Interaction of smart grid and phasing device.

But long-term operation of this device is undesirable at low power consumers. Additional losses of energy can occur due to differences in the supply voltage of the substation, also the losses in the phasing device should be taken into account. Therefore, automatic intelligent control is necessary with parallel power. The smart grid will collect and analyze information about the state of the load, and will make the decision to turn on the phasing device. In such cases, the mode of operation of the system will be more profitable.

II. METHODS

Experimental study of power quality was carried out at the point where the non-traction consumer was connected to the TWR line in different modes. The analysis of the measured parameters is performed using the methods of mathematical statistics.

The experiment purpose is to evaluate the advantages of line TWR with double-sided supply in terms of the power quality.

The experiment was conducted on the territory of the Odes'ka railway, where, in total, there are two lines of TWR, which are able to work on both sides, due to their geographical location

TWR line is normally powered from the traction substation Chubivka. Reserve supply is from the substation Slobidka (Fig. 4). During the experiment the line was received power from two substations simultaneously and separately from each substation. Each mode was operated for three hours. Total duration of the experiment was 9 hours.

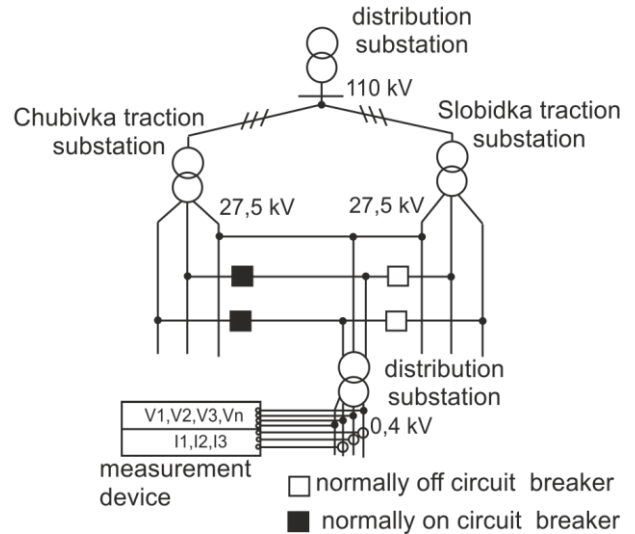

Fig. 4. Measurement scheme

The first mode was corresponded to the normal power scheme (time range from 6:00 to 9:00 o'clock), the distance between the measuring point and the Chubivka traction substation along the line is about 50 km. The second mode was applied from 12:00 to 15:00 o'clock, at that time supply was realized from two substations. In the third mode the load was powered from the substation Slobidka with distance to substation is about 3 km.

The portable electric power quality analyzer ELD-175xr (Satec) was used to measure current and voltage at discrete points in time. Instrument characteristics are summarized in the table I.

TABLE I. INSTRUMENT CHARACTERISTICS	
<b>Instrument metrological parameters</b>	
current measurement range	30 – 3000 A
maximum measured voltage	660 V
accuracy class	0,2
<b>Measured Parameters</b>	
RMS (root mean square) voltage and current per phase	neutral current
kw, kvar, and kva per phase	total kw, kvar and kva
power factor per phase	total power factor
frequency	voltage and current unbalance
harmonic measurements	min/max logging
energy per phase	total energy

The measuring device is connected to the input of 0.4 kV transformer substation, where the TM-400 kVA 25 / 0.4 kV transformer is installed.

### III. ANALYSIS OF THE EXPERIMENTAL RESULTS

Overview measurement results and static data analysis are described further in the article.

Real electrical currents and voltages are stochastic. It happens that the relationship is stronger than usual, for example, between V1 and I1 in the first mode from 6:00 to 9:00 in Figs 5 and 6.

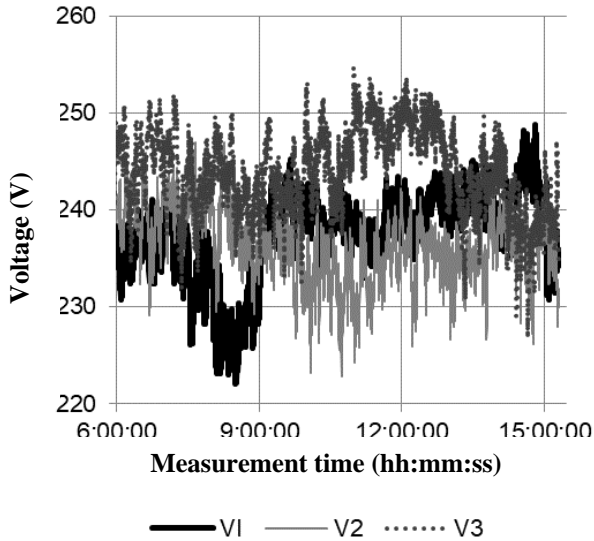

Fig. 5. Voltage measurement in three phases

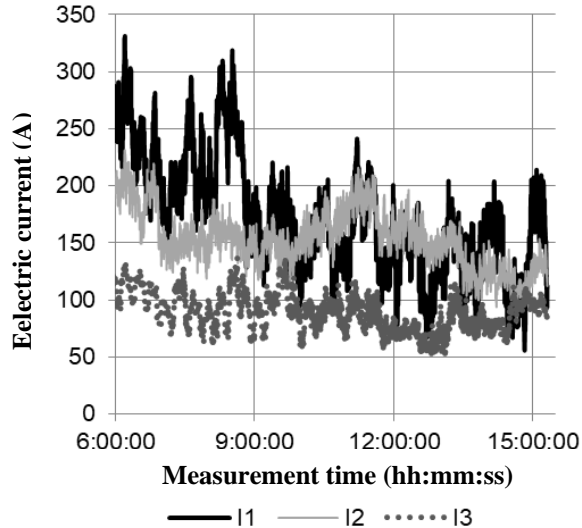

Fig. 6. Measured currents in three phases

Pearson correlation (1) is used to determine the degree of linear relationship between current and voltage in each phase (table II).

$$r_{X,Y} = \frac{\sum_{i=1}^n (X_i - \bar{X}) \cdot (Y_i - \bar{Y})}{\sqrt{\sum_{i=1}^n (X_i - \bar{X})^2 \cdot \sum_{i=1}^n (Y_i - \bar{Y})^2}}, \quad (1)$$

where  $r_{X,Y}$  is Pearson correlation coefficient,  $X_i, Y_i$  are random variables for  $i=1, 2, \dots, n$ ,  $n$  is sample size,  $\bar{X}, \bar{Y}$  are sample means.

TABLE II. CORRELATION BETWEEN VOLTAGE AND CURRENT

Time interval	corr(V1,I1)	corr(V2,I2)	corr(V3,I3)
6:00-9:00	-0,39	-0,13	-0,26
9:00-12:00	-0,58	-0,25	-0,54
12:00-15:00	-0,76	-0,16	-0,70

The calculation results show that the strongest linear connection occurred during the power supply from the Chubivka substation, but this method also showed that in the majority of cases the relationship between the quantities is weak.

Total harmonic voltage distortion diagram also shows the improvement in the quality of energy supply in the parallel mode (Fig. 7). The average value of the distortion in the three modes is shown in table III. The average THD (total harmonic distortion) in phases decreased relative to one in the first mode by 0.82, 0.65 and 0.29 %. In the third mode, the average value increased from 0.06 to 0.3%.

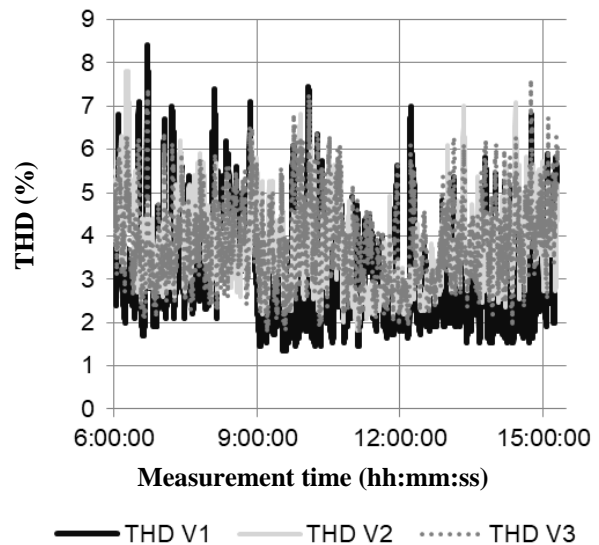

Fig. 7. Total harmonic voltage distortion factors

TABLE III. TOTAL HARMONIC DISTORTION

Time interval	Average THD, %		
	V1	V2	V3
6:00-9:00	3,85	4,01	3,99
9:00-12:00	3,03	3,36	3,70
12:00-15:00	2,77	3,63	3,76

The THD is defined the following equation [7]:

$$THD = \sqrt{\sum_{i=1}^n V_n i^2} \quad (2)$$

where  $V_n$  is ratio of the RMS (root mean square) amplitude of voltages a set of higher harmonic frequencies to the RMS amplitude of the first harmonic, or fundamental, frequency,  $i$  is voltage harmonic number.

The relative deviation of the mean square value from average of the three phases is shown in the Fig. 8 and Fig. 9. The differences between the phase currents and the voltages on them are shown visually. The size of the markers is the function of the voltage deviation.

The following formula was used for this calculation:

$$Marker\ size \propto \frac{\bar{V} - V_i}{V_i} \cdot 100\% \quad (3)$$

where  $\bar{V}$  is average voltages or current of three phases,  $V_i$  is line to earth voltage or current in line,  $i$  is line phase number.

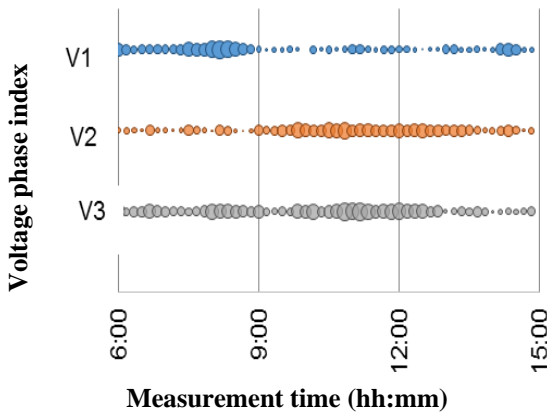

Fig. 8. Ratio of voltages in each phase

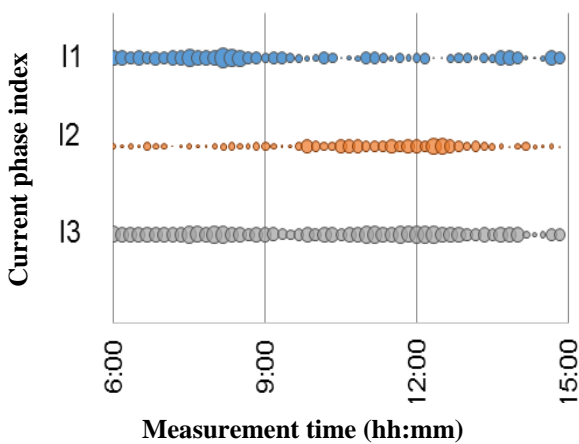

Fig. 9. Ratio of currents in each phase

The voltage deviation in the phases was from 225 to 250 V. The pattern of influence on this indicator of the line is not fixed in different modes.

The power quality is improved during a double-side supply in the 9:00 – 12:00 hours range (Fig. 10), during this period the voltage is more balanced.

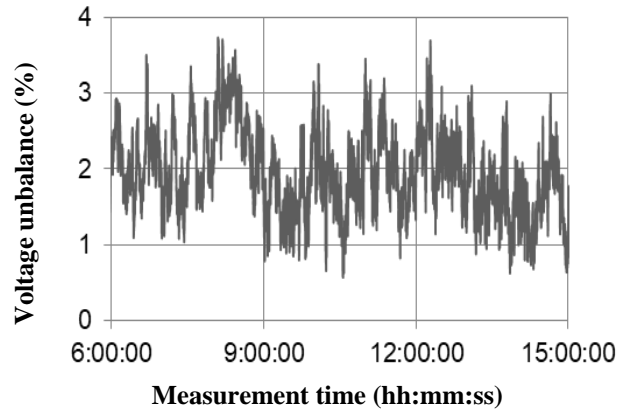

Fig. 10. Voltage unbalance

The results of statistical processing of unbalance voltage in graphical form are shown in Figs. 11-14. The average unbalance in the second mode differs from the first one by 0.5% and from the third one by 0.32%. In the second mode, the voltage unbalance deviation is less than the average compared to the first and last mode.

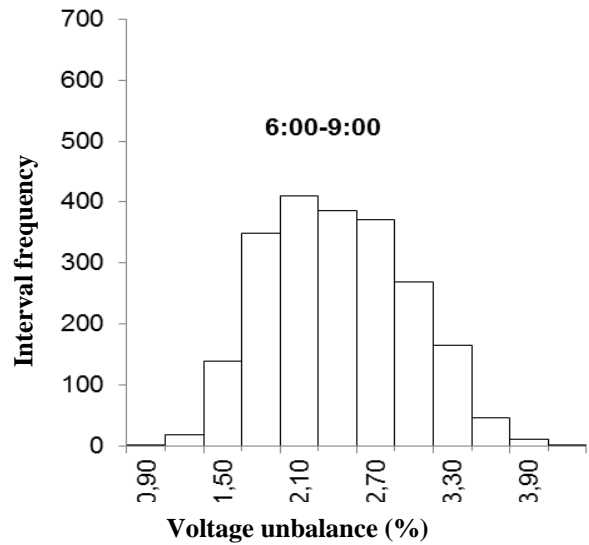

Fig. 11. Frequency of voltage unbalance in first mode

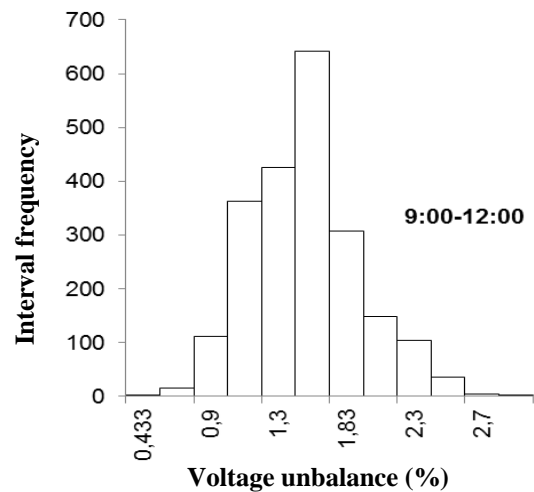

Fig. 12. Frequency of voltage unbalance in second mode

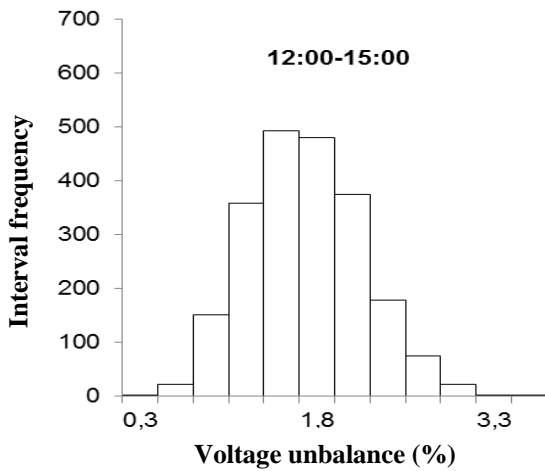

Fig. 13. Frequency of voltage unbalance in third mode

The number of intervals  $N$  in the variation series is calculated using the Sturges rule

$$N = 1 + \log_2 n, \quad (4)$$

where  $n$  is total number of observations. It was total 10 800 observations in three modes of power supply.

The confidence interval was calculated for the mean and values are given in the table IV

$$\left( \bar{x} - t \frac{s}{\sqrt{n}}; \bar{x} + t \frac{s}{\sqrt{n}} \right), \quad (5)$$

where  $\bar{x}$  is sample mean,  $t$  is Student distribution critical value,  $s$  is corrected standard deviation,  $n$  is total number of observations.

Number of exceeding the voltage unbalance limit should be no more than 95% of the total number over the measurement period. The cumulative distribution function (Fig. 14) was calculated to test this condition. It visually shows the unbalance in different modes.

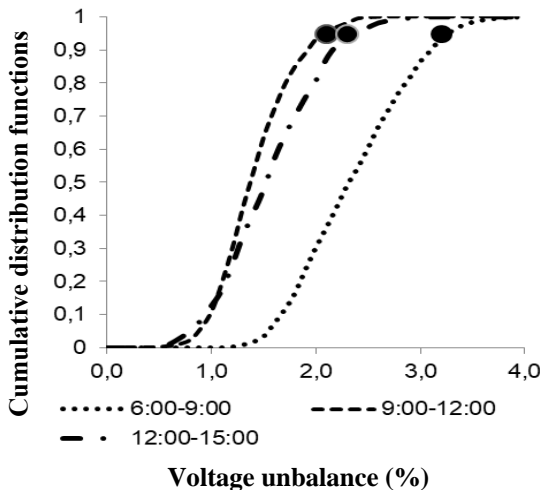

Fig. 14. Cumulative distribution functions for voltage unbalance for each mode

An assessment of the effect of current unbalance on voltage unbalance was carried out additionally. The correlation method gave a weak statistical dependence, therefore, we accepted that these unbalances of current and

voltage are independent variables, which simplifies further analysis.

TABLE IV. CONFIDENCE INTERVAL FOR MEEN VOLTAGE UNBALANCES

Time interval	Mean	Confidence interval	
		lower bound	upper bound
6:00-9:00	2,25	2,23	2,271
9:00-12:00	1,41	1,39	1,42
12:00-15:00	1,55	1,53	1,57

Joint probability distributions of current and voltage unbalance are presented in the last three diagrams (Fig. 15-17). The points with the same probability density values were crossed by isolines.

Reducing the range of unbalanced currents shown in the diagram during the second mode, and the voltage unbalance was decreased too, but on a lesser degree.

Note, that the requirements of the standard were used in the analysis of the quality of electricity, except for the requirements for the duration of measurements. Therefore, it is impossible to conclude about the quality of the experiment.

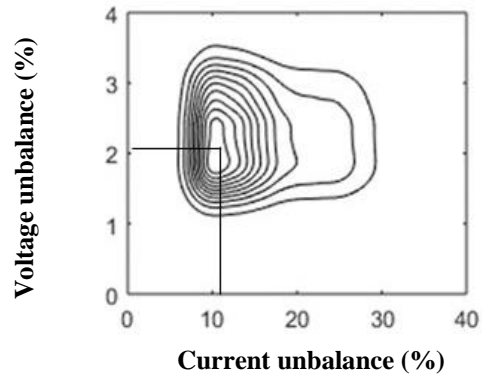

Fig. 15. The joint probability density of the voltage and current unbalances in the first mode

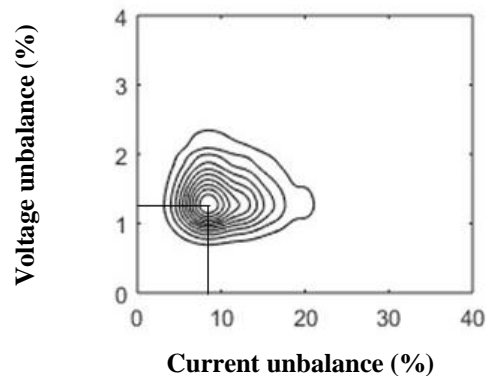

Fig. 16. The joint probability density of the voltage and current unbalances in the second mode

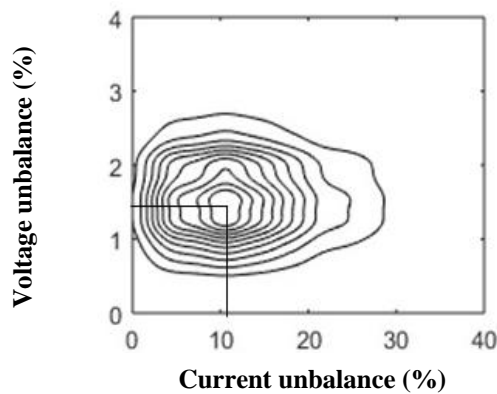

Fig. 17. The joint probability density of the voltage and current unbalances in the third mode

### CONCLUSIONS

Competition between energy companies due to the liberalization of the electricity market may increase. At the same time, there are local distribution networks that can degrade the reliability of transmission of electrical energy, first of all it concerns TWR lines. Phasing different parts of power supply systems with different vector voltage groups is a potential way to increase electrical energy quality and reliability of supply. At the same time, the operation of the phasing device causes additional losses of energy in the system, and the flow of power between adjacent substations due to different voltages in transformer terminals. By using the concept of smart networks problem solving is achieved.

The reliability of the research results is provided by the accuracy class of the measuring device. Accuracy of the results was assessed by confidence interval with using Critical Value for Student's t-Distribution. Results can be used to validate the parameters and configuration of a mathematical model. The expected positive effect due to the operation with power on both sides is shown in the research.

The load that was studied did not significantly affect the voltage level, although it had a significant asymmetry of the currents. But the quality of electricity has increased on the

consumer due to the influence of all loads. During the power supply from both sides, the voltage unbalance and THD were reduced on 0.5 % (average) and 0.8 % (maximum).

### REFERENCES

- [1] M. Bollen and I.Y.H. Gu, *Signal Processing of Power Quality Disturbances*. N.J.: IEEE Press Publ., 2006.
- [2] B. K. Panigrahi, and A. Comparative, "Study of Signal Processing and Pattern Recognition Approach for Power Quality Disturbance Classification," *IETE J Res*, no. 57, pp. 5-11, 2011.
- [3] P. E. Sutherland, "System impacts evaluation of a single-phase traction load on a 115 kV transmission system," *IEEE Transactions on power delivery*, vol. 21, no. 2, pp. 837-843, 2006.
- [4] T. E. Finochenko, "Power quality of the TWR lines under the influence of the magnetic field of the traction current," *Vestnik Rostovskogo gosudarstvennogo universiteta putei soobshchenia*, no. 3 (23), pp. 90-93, 2006.
- [5] D. O. Bosiy, "Power quality complex estimation at alternating current traction substations, Science and Transport Progress", *Bulletin of Dnipropetrovsk National University of Railway Transport*, no. 4 (46), pp. 30-37, 2013.
- [6] The Cabinet of Ministers of Ukraine, Energy Strategy of Ukraine until 2035 "Security, energy efficiency, competitiveness," Government Courier, 2017.
- [7] DSTU EN 50160:2014 "Voltage characteristics of electricity supplied by public electricity networks (EN 50160:2010, IDT)," Kyiv : State Enterprise "UkrNDNTs", 2014.
- [8] Ja. Ekanayake, K. Liyanage, J. Wu, A. Yokoyama, and N. Jenkins, *Smart Grid technology and applications*, John Wiley & Sons, 2012.
- [9] M. Bollen, *The Smart Grid: Adapting the Power System to New Challenges*, Morgan & Claypool, 2011.
- [10] M. Bollen, R. Das, S. Djokic, P. Ciufu, J. Meyer, SK. Rönnerberg, and F. Zavadam, "Power quality concerns in implementing smart distribution-grid applications," *IEEE Transactions on Smart Grid* no. 8 (1), pp 391-399, 2017.
- [11] X. Fang, S. Misra, G. Xue and D. Yang, "Smart Grid — The New and Improved Power Grid: A Survey," *IEEE Communications Surveys & Tutorials*, vol. 14, no. 4, pp. 944-980.
- [12] S. Cui, Q. Yu, G. Gu, and Q. Gang, "Research on the architecture of electric power information communication network for smart grid," *2017 IEEE Conference on Energy Internet and Energy System Integration (EI2)*, Beijing, China, 2017, pp. 1-4.